



DesIRE

MODERNIZATION OF MOBILE OBJECT CONTROL SYSTEM BASED ON RASPBERRY PI AND ARDUINO PLATFORMS

Anzhelika Parkhomenko, Oleksii Kravchenko,
Dmytro Kravchenko, Olga Gladkova
Zaporizhzhya National Technical University,
Ukraine



DESIRE SYMPOSIUM, Nitra, 12-14 September, 2016

Outline

- ▶ Mobile object control systems
- ▶ FPV Auto Project description: Shortcomings and Problems
- ▶ Project modernization based on Raspberry Pi platform
- ▶ Project modernization based on Arduino platform
- ▶ Conclusions / Future work
- ▶ Questions

Mobile objects control systems

Basic software requirement:

- minimum response time for input parameters;

Basic hardware requirements:

- compactness;
- energy consumption minimization.

Basic system requirements

- expected behavior of the system;
- reliability;
- durability.

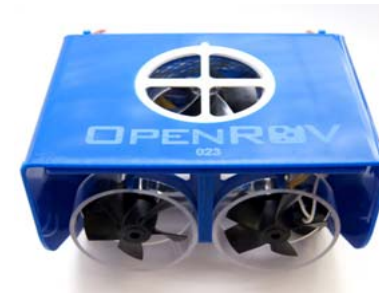

FPV Auto Project demonstration, Zaporizhzhya, October 15, 2015



DESIRE SYMPOSIUM, Nitra, 12-14 September, 2016

FPV Auto project

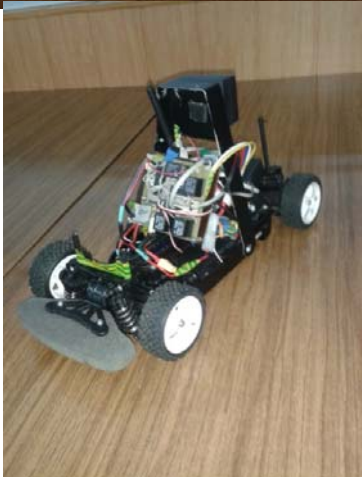
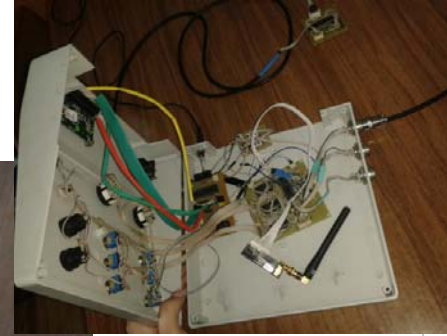

FPV Auto project: Systems architecture

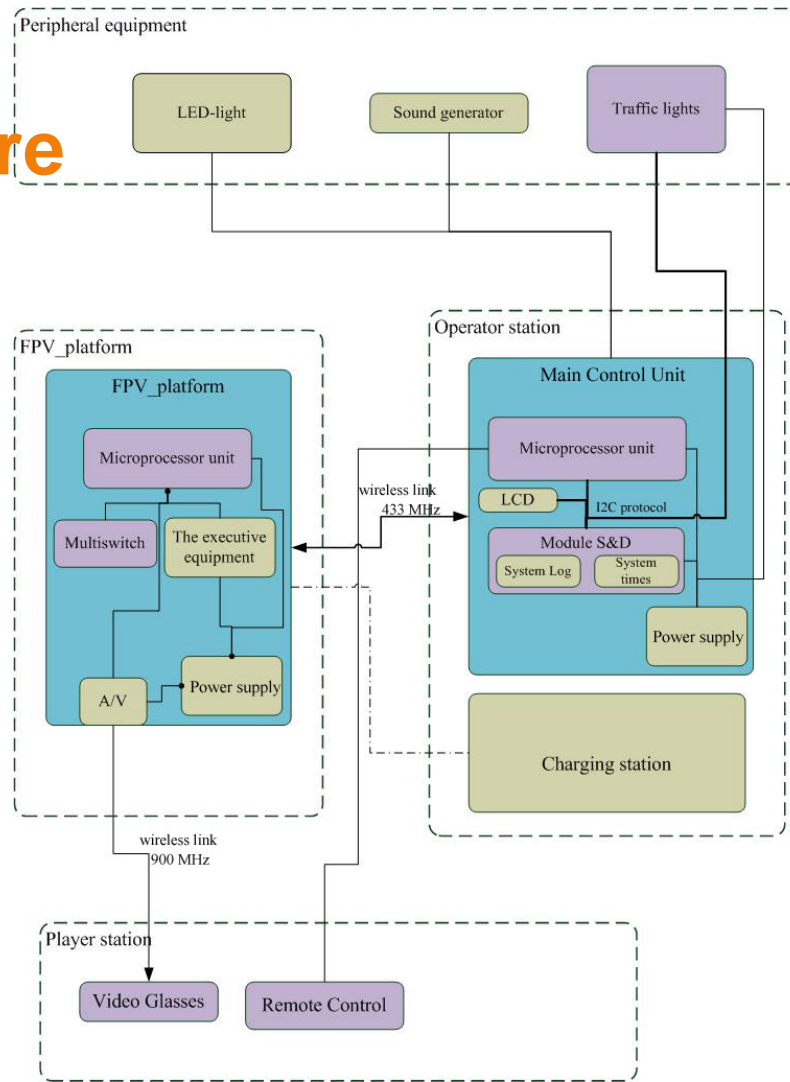

- Programmable components
- Completed solutions
- Constructive components

FPV Auto project: Shortcomings and Problems

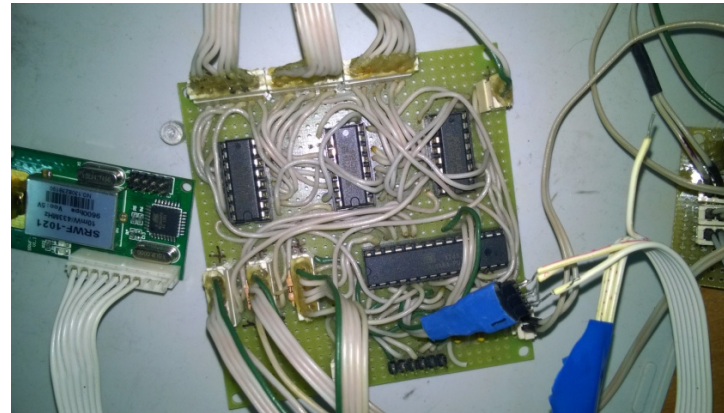

Modern platforms and ECAD systems

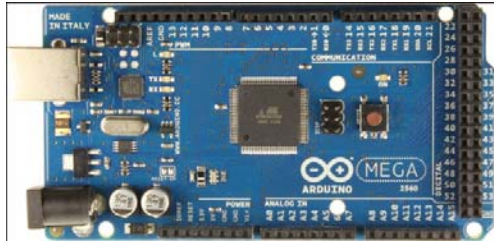

Arduino



Raspberry Pi



Intel Galileo

Altera Cyclone

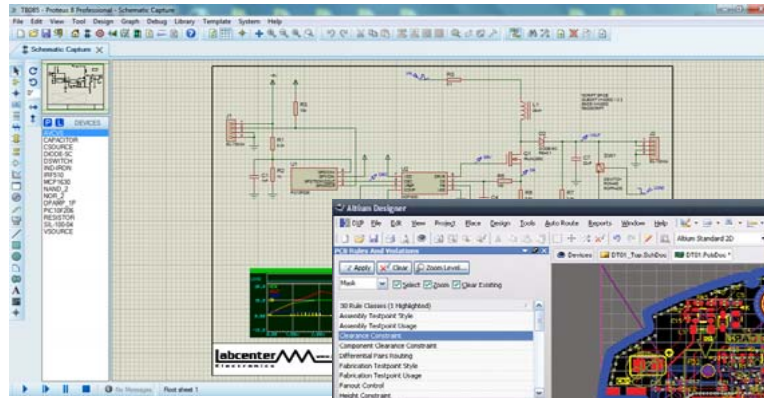

Proteus

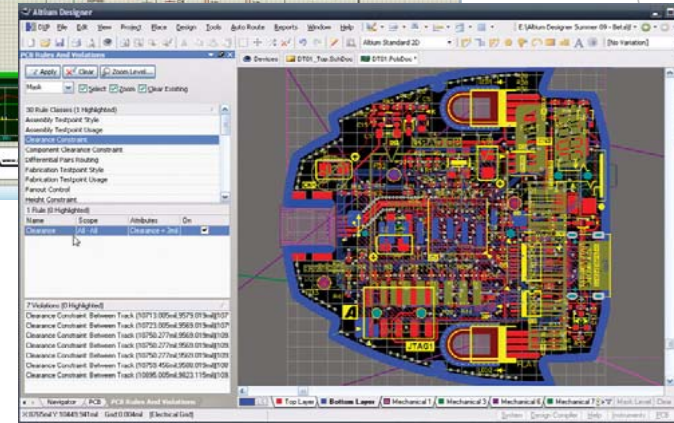

Altium Designer

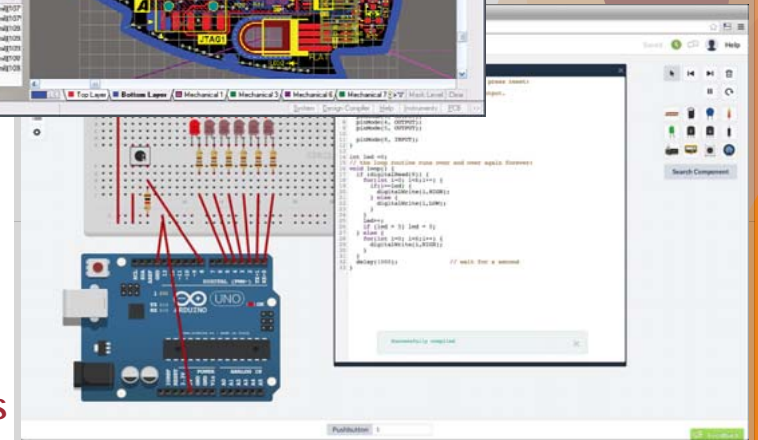

123D Circuits

FPV Auto Project modernization based on Raspberry Pi platform and Altium Designer

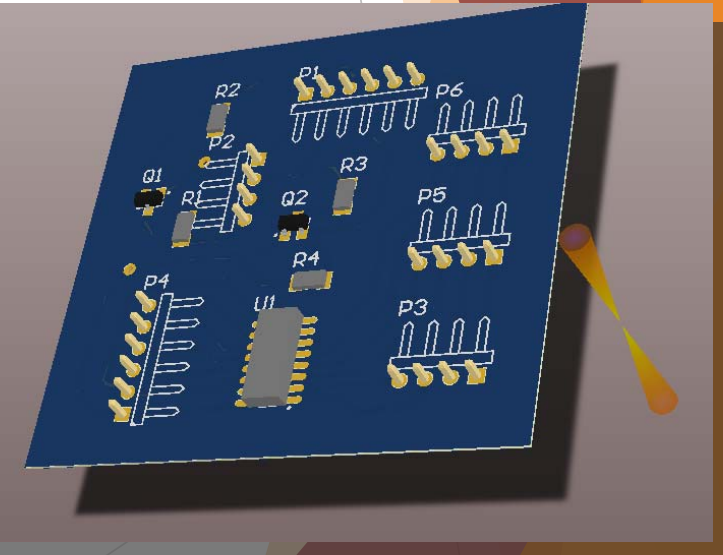
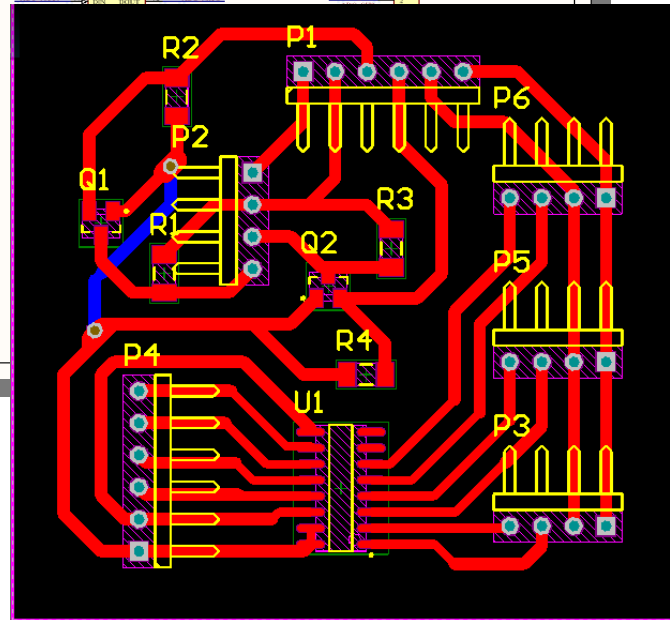
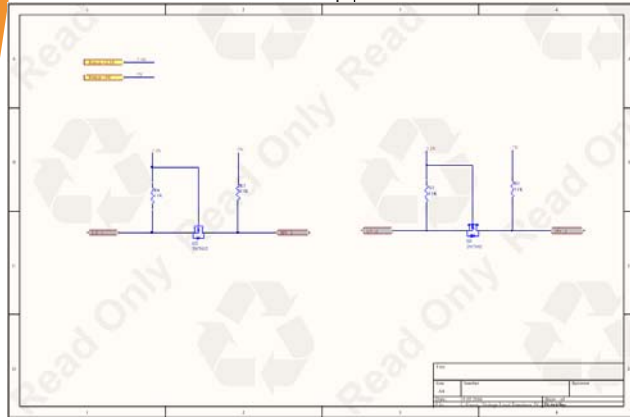
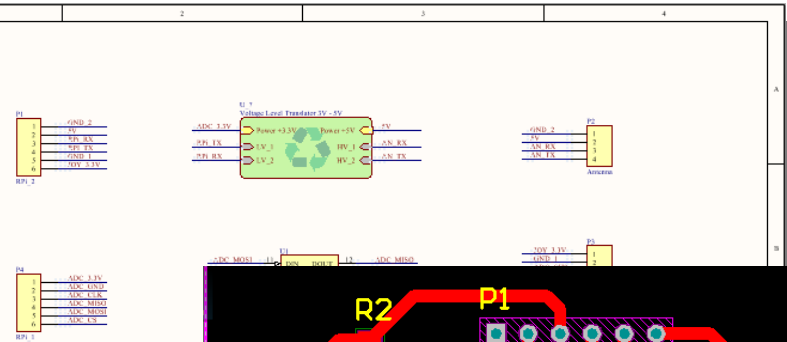

FPV Auto Project results: software

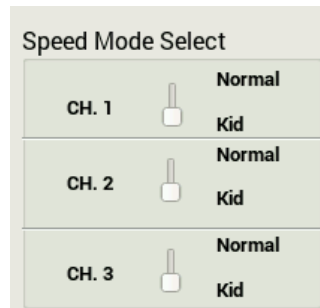
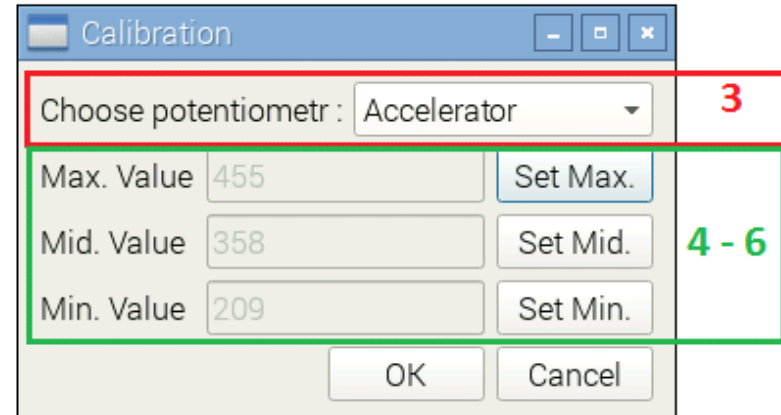
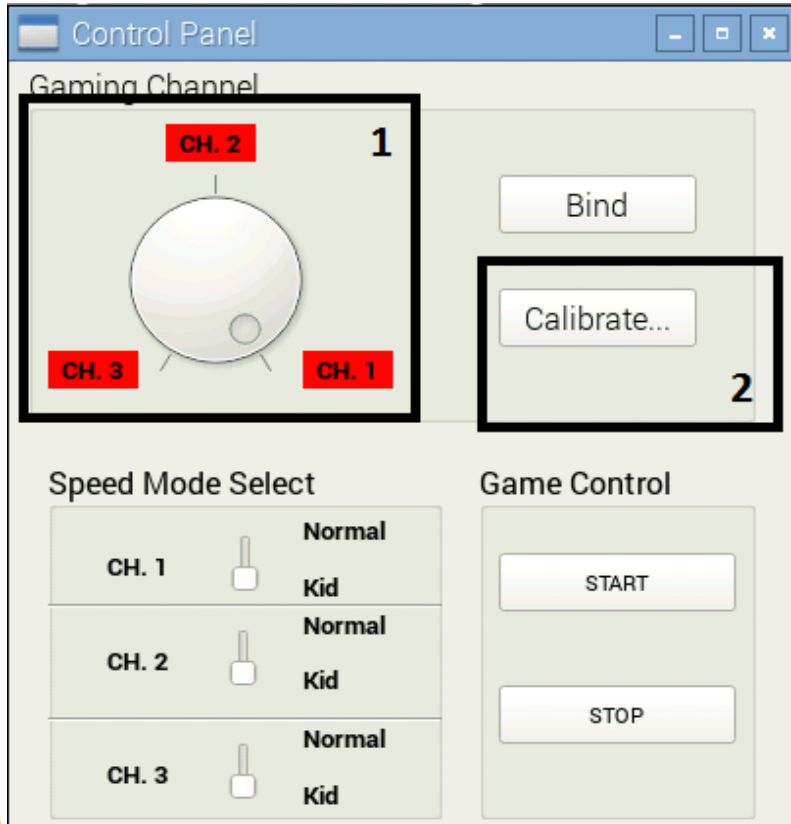

FPV Auto Project results: hardware testing



FPV Auto Project modernization based on Arduino platform and Proteus

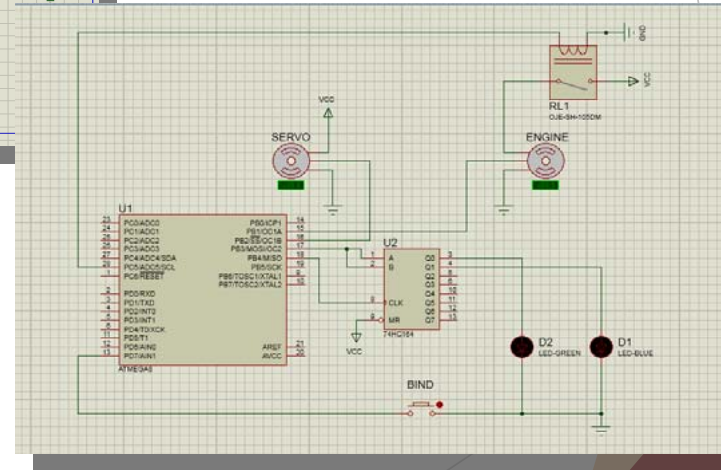
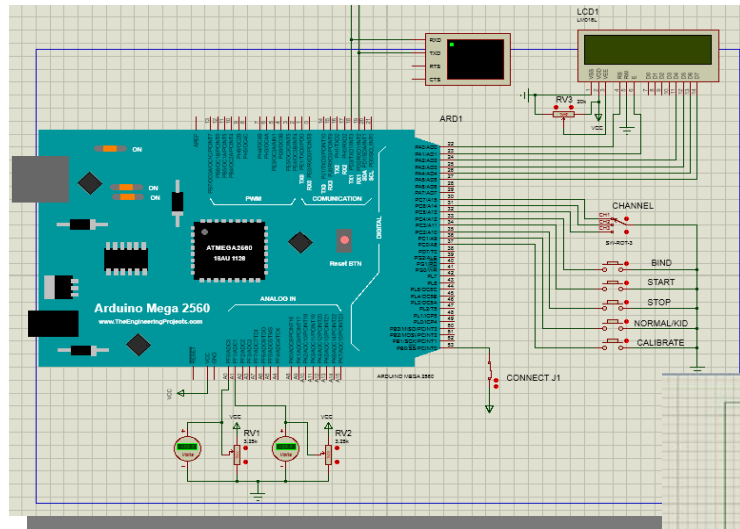
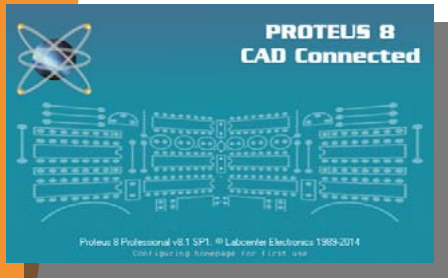

FPV Auto Project results: software

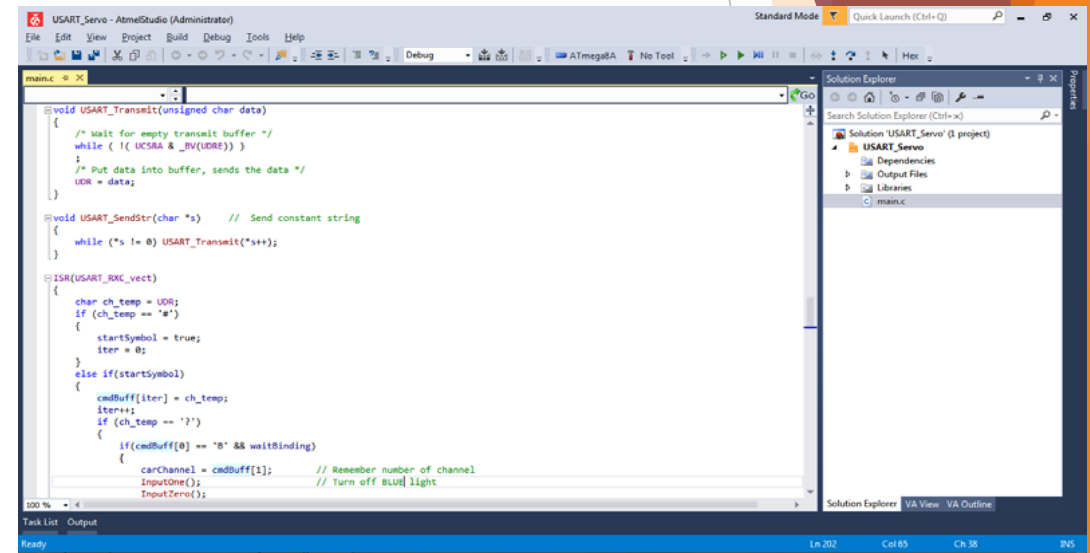
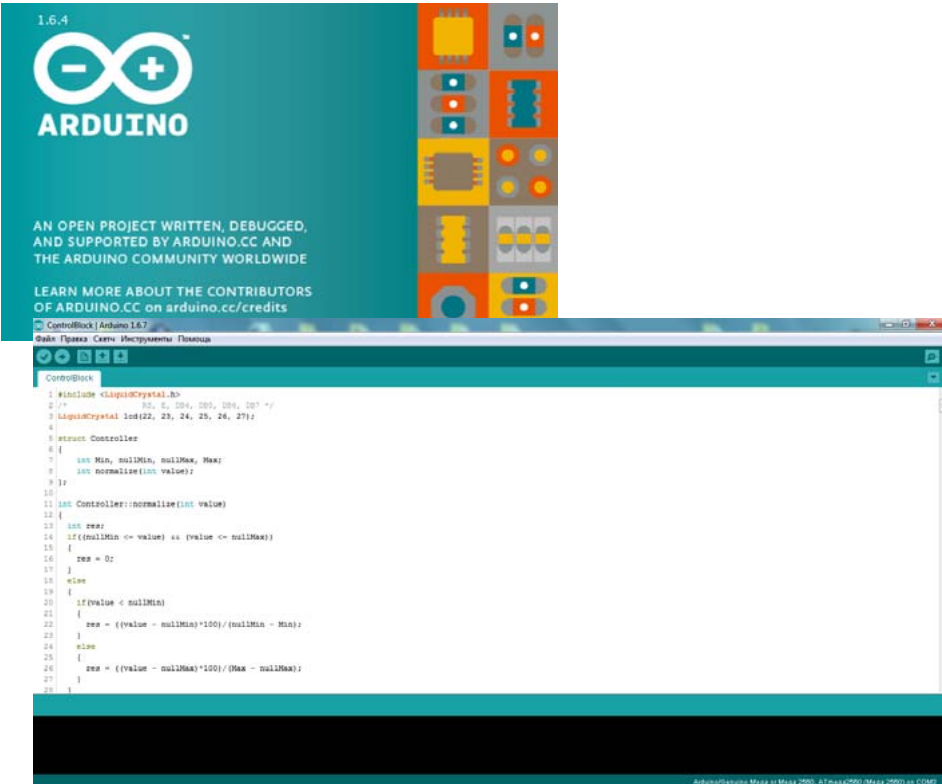

FPV Auto Project results: hardware testing

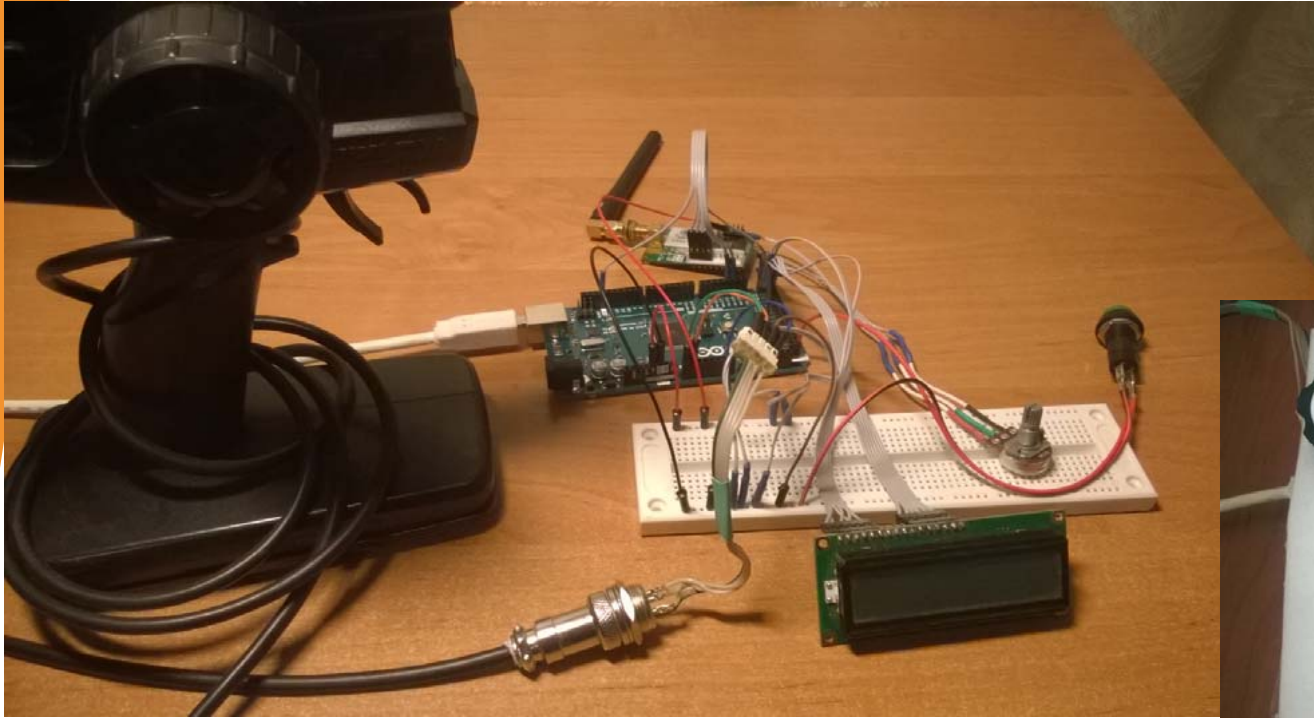

Work in progress

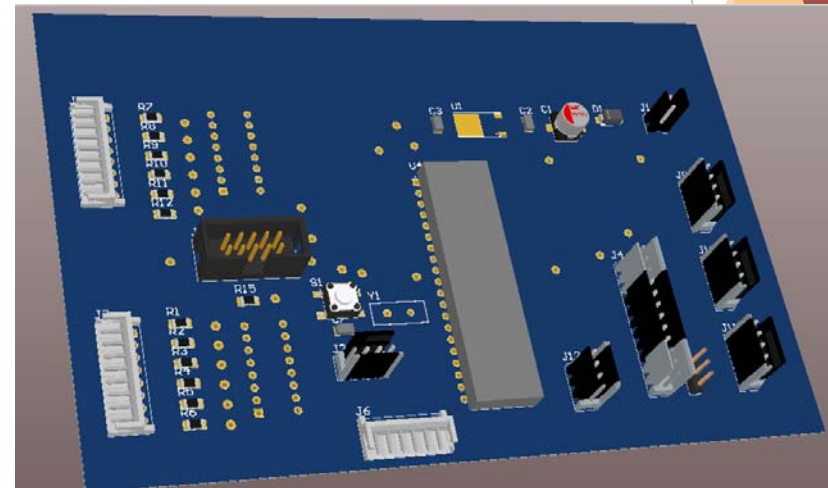
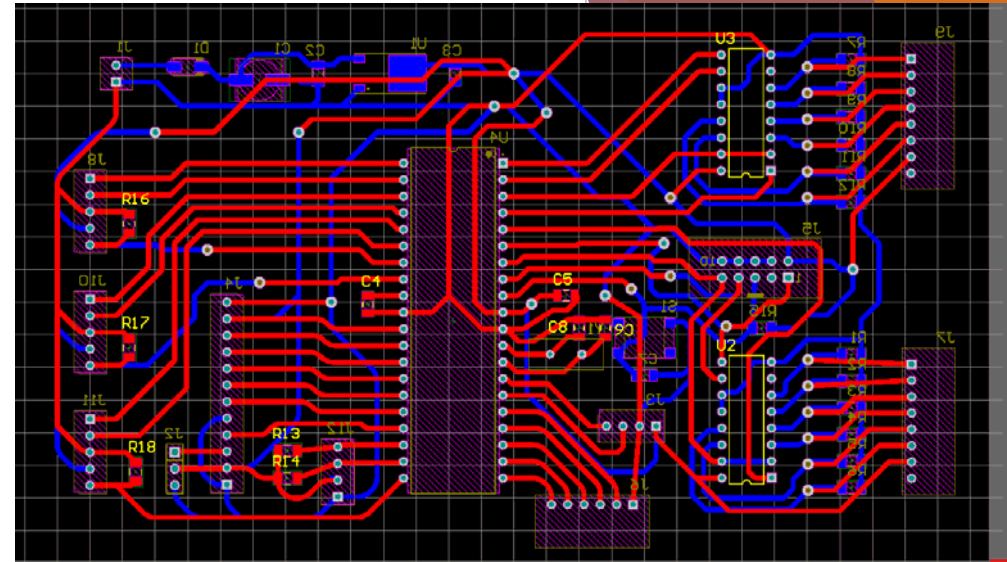
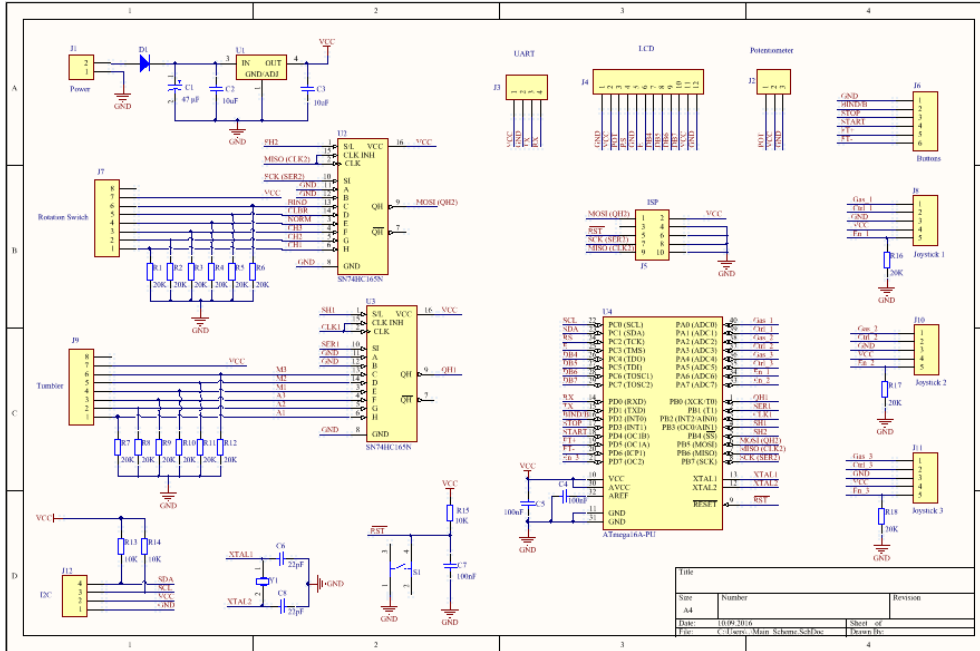

FPV Auto Project results: demonstration of Bachelor's degree works, May, 2016

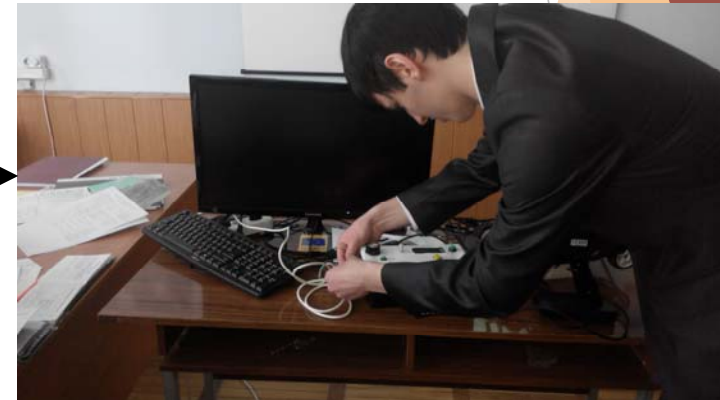
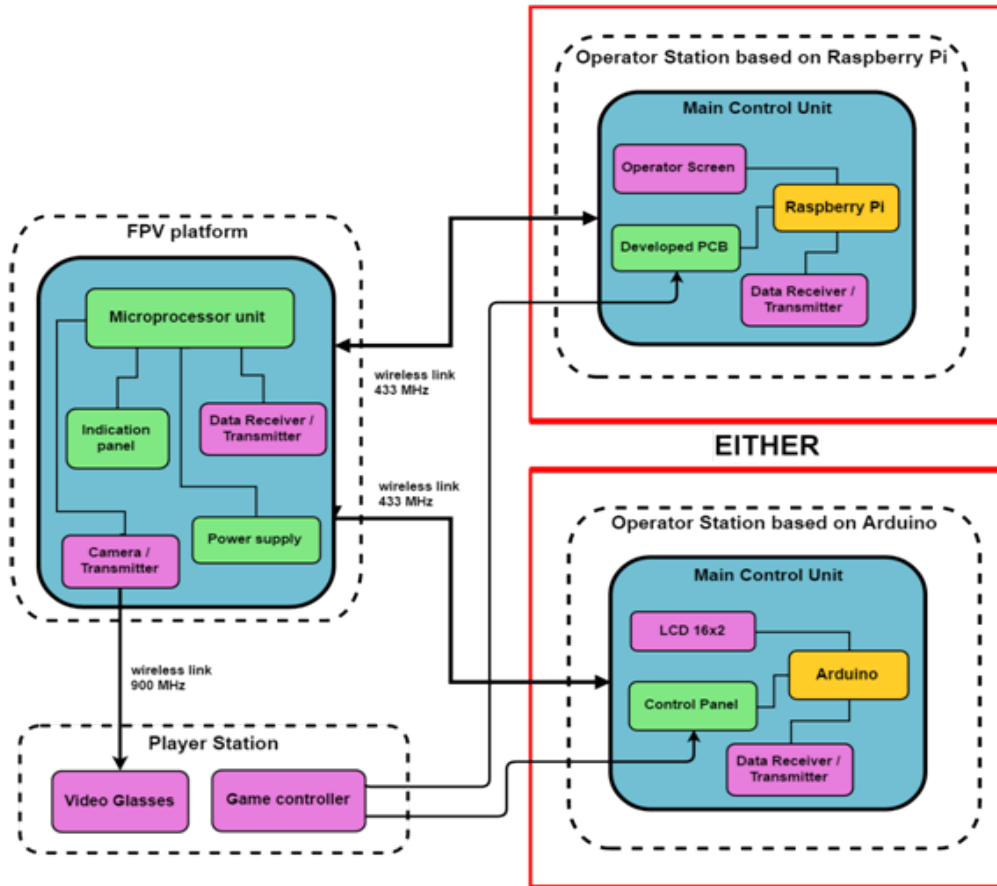

EITHER

Conclusions

- Testing the real prototypes showed that both implementations work stable but has its own advantages and disadvantages.
- As a result of the project – FPV Auto system failures have been eliminated, systems reliability increased, quality of the video transmitted to the player glasses improved.
- Implementation of real projects gives students invaluable practical experience and knowledge, motivation to research, to work in team, to communicate with the customer, to present the results of their work to an audience.

THANK YOU FOR YOUR ATTENTION!



DESIRE SYMPOSIUM, Nitra, 12-14 September, 2016